

TO-551AS-E

Fashion Pants Topper

New Feature, Automatic Clamp

Automatic Opening Clamp

- When pressing a tuck, automatic clamping by means of stepping a pedal enables an easy and neat setting of pants without using the hands.
- When this process is finished, the clamp automatically opens, and finished pants can be easily taken out.
- Manual operation enables clamping at an arbitrary place.

The system achieving high performance and quality finishing

- High capacity blower motor, enhanced to 400W, achieved high quality finishing and high productivity.
- Adopted the airbag bringing about an ideal waist shape and the best bulge.
- Added a new feature to select a free stop position of waist tension which is the most suitable to a delicate finish for a knit and so on.
- Widely available to waist size ranging from 68 to 125 cm.

Skirt clamp to automatically detect a position

- Achieved clamping to detect the edge of a skirt automatically.
- When using the feature to pull a skirt during finishing, shrinkage of texture can be prevented in addition to the wrinkle smoothing feature.
- As to tension degree to a skirt, it is selectable from three phases among "null", "short" and "long".



MAJOR SPECIFICATION

Integrated Technology for the Machine

Model	TO-551AS-E	
Product name	Fashion Pants Topper	
Power supply	Voltage	3 phase AC400V
	Hz	50Hz
	Power consumption	0.4 Kw
	Blower	0.4 Kw
Steam	Standard pressure	0.5 MPa
	Max.	0.6 MPa
	Consumption	20 kg/h
	Inlet	15 A (1/2 inch)
	Outlet	15 A (1/2 inch)
Air	Air consumption	5 L/time (ANR)
	Pressure	0.5 MPa
	Inlet	6 A (1/8 inch)
Dimension	Waist size	68 – 125 cm
	Width	780 mm
	Depth	1000 mm
	Height	1728 mm
Weight Weight	112 kg	

*Specification set forth on this catalogue is subject to change without prior notice.

Front View (mm)

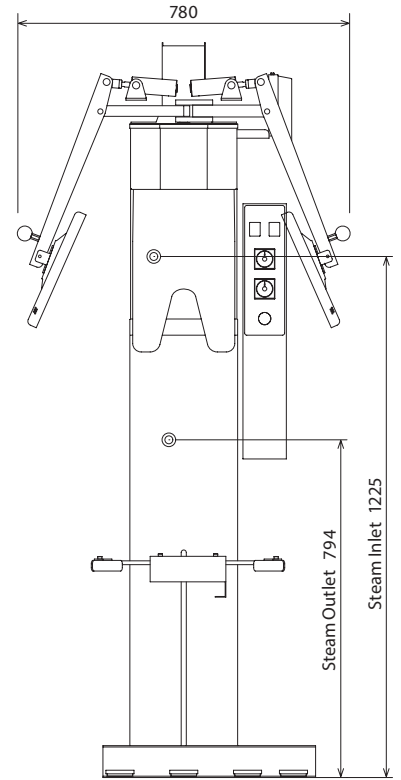

Right Side View (mm)

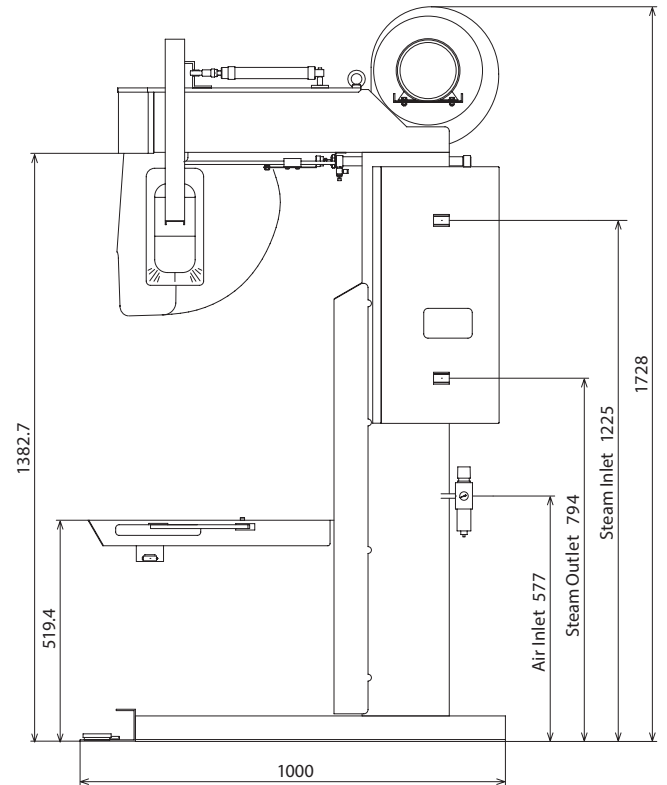

ITSUMI MANUFACTURING CO., LTD.

3670 KASAHATA KAWAGOE CITY SAITAMA 350-1175 JAPAN TEL:+81-49-231-1799 FAX:+81-49-231-9079

e-mail: info@itsumi.co.jp <http://www.itsumi.co.jp>